

DIY OUTDOOR TABLE PLANS - ROOTS AND WINGS FURNITURE

VIDEO: https://www.youtube.com/watch?v=qUB3LE_LrRY

LEG CUT LIST

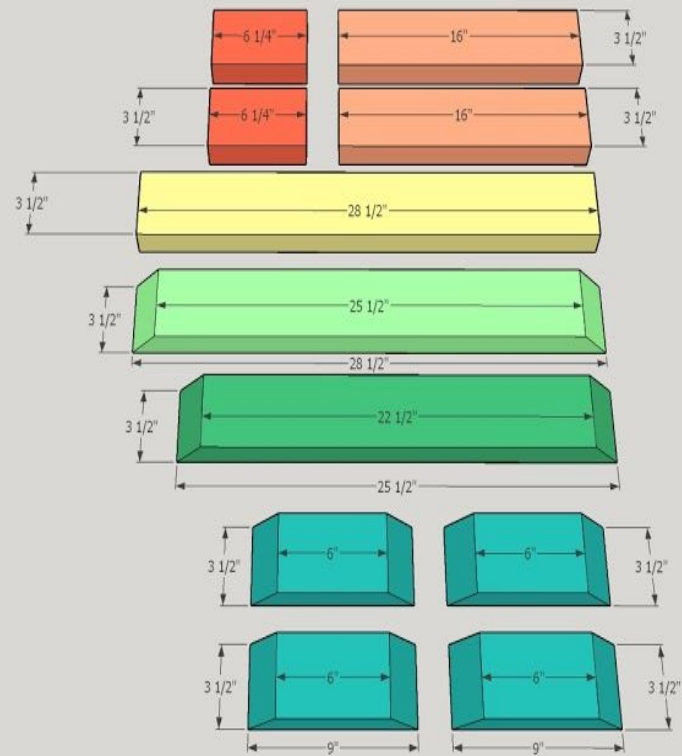

STEP 1: BUILD THE COLUMNS OF THE BASE

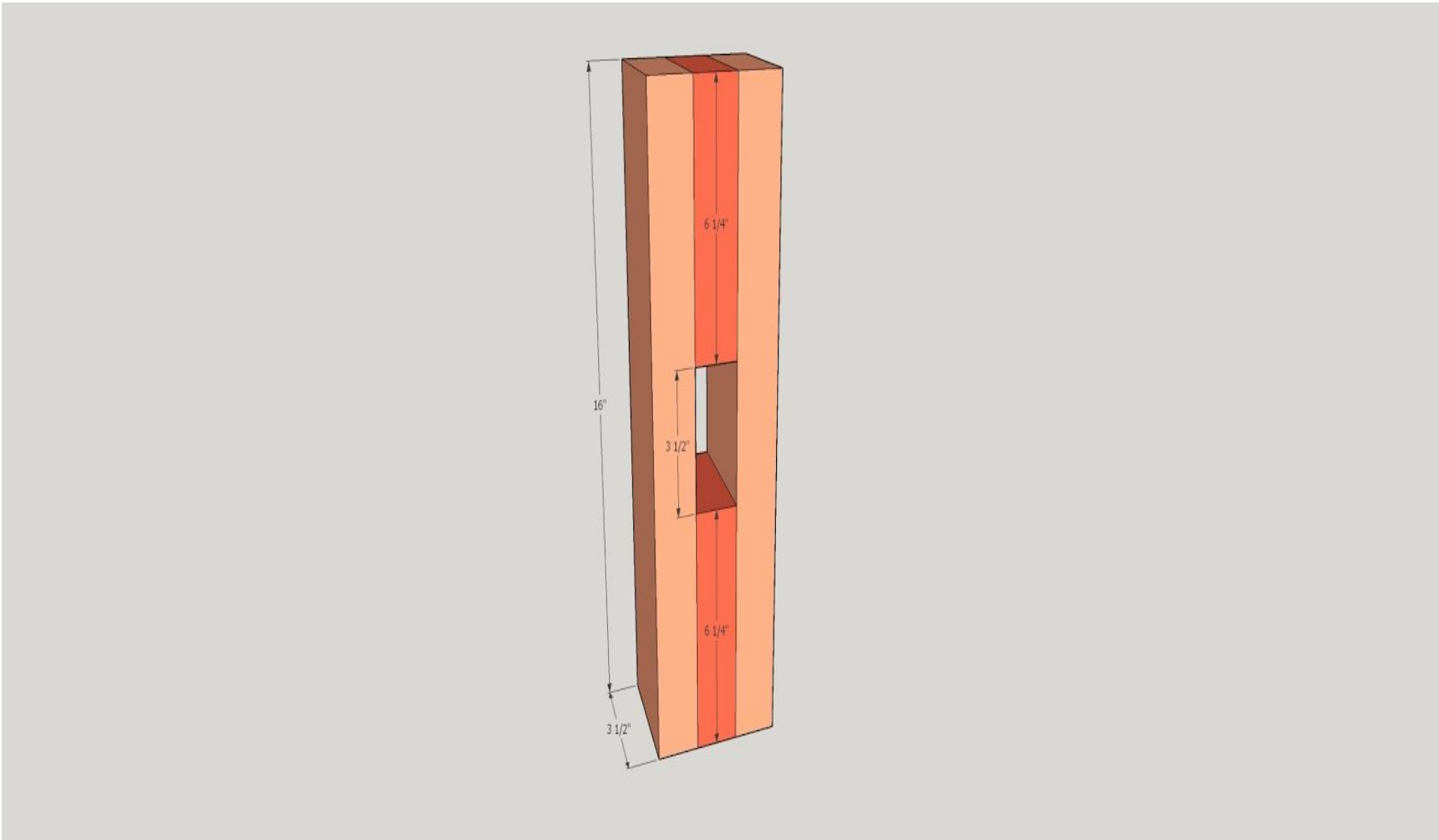

STEP 2: ADD THE TABLE SUPPORT

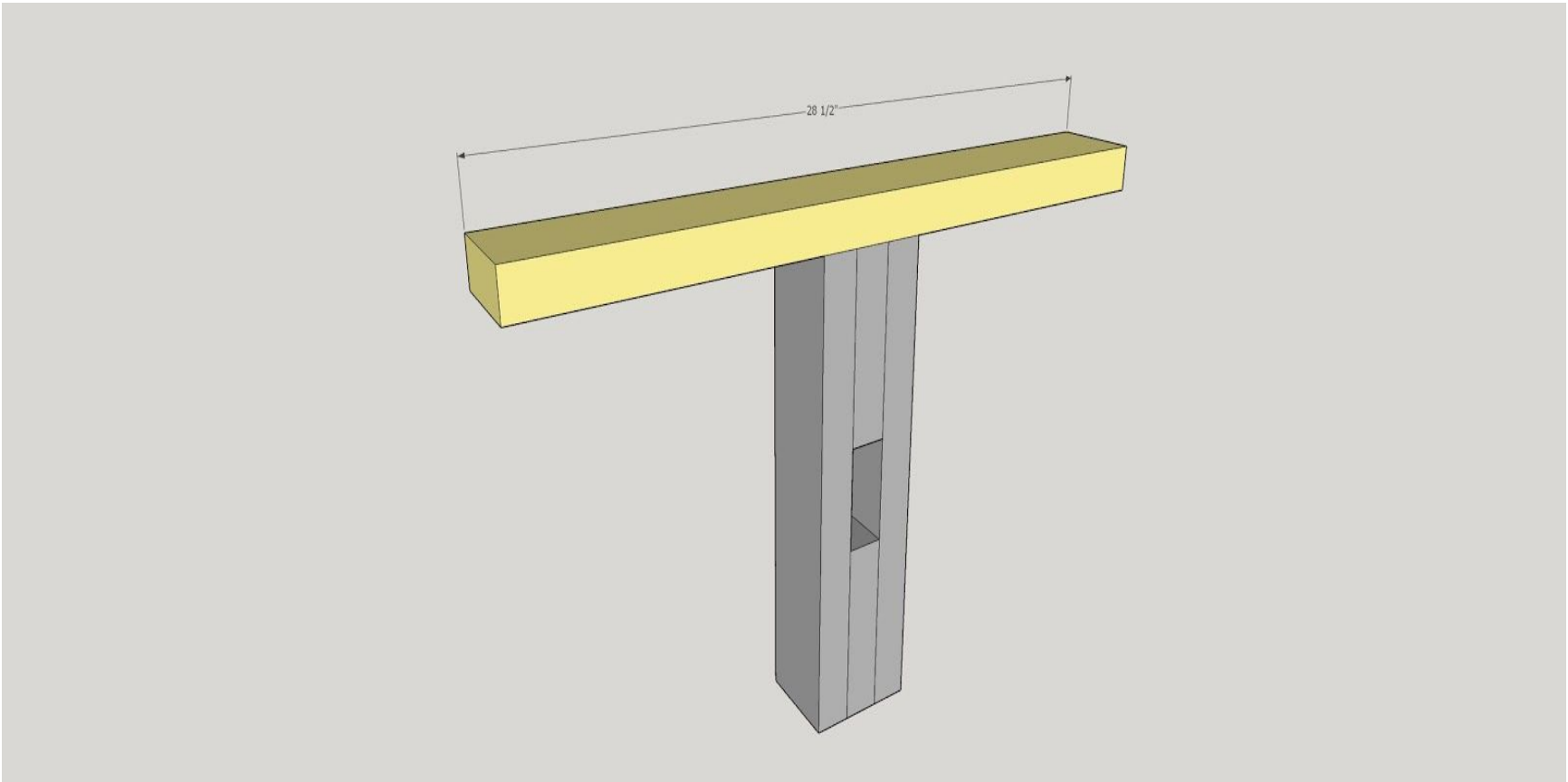

STEP 3: ADD THE LEGS, DO ONE BOARD AT A TIME.

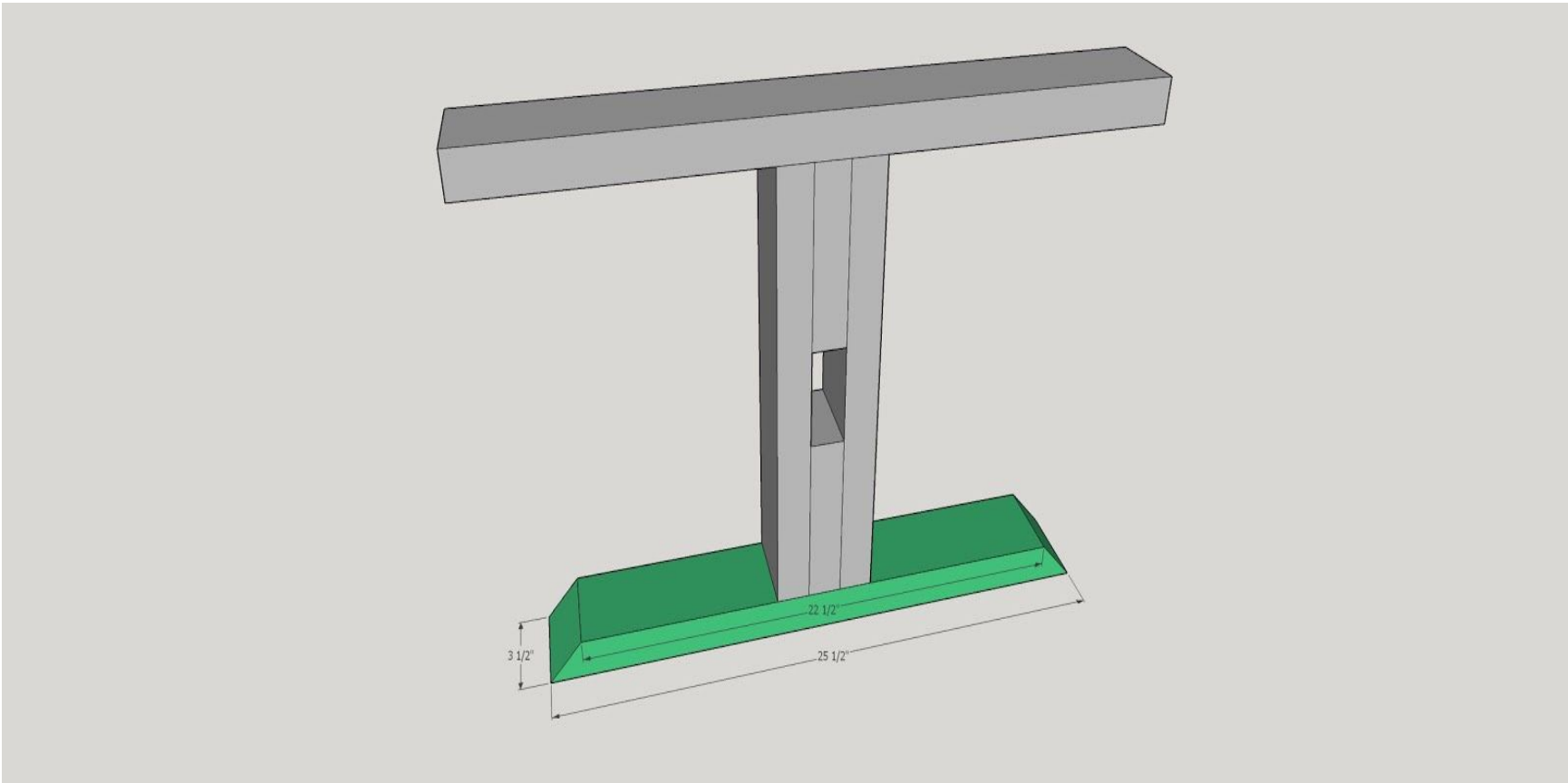

STEP 4: ADD THE BASE FOOT BOARD

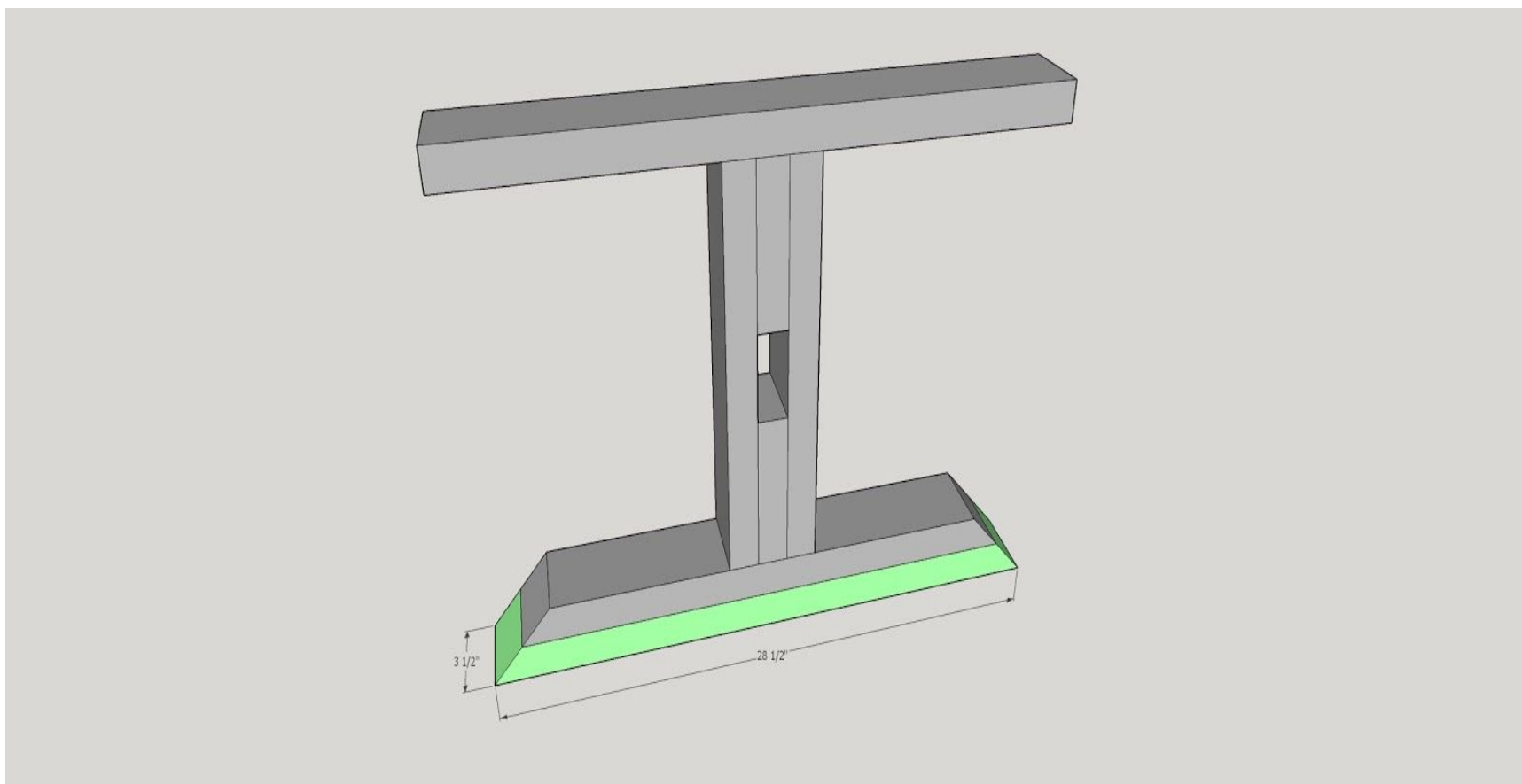

STEP 5: ADD THE SUPPORT ANGLED PIECES USING GLUE AND A NAIL GUN.

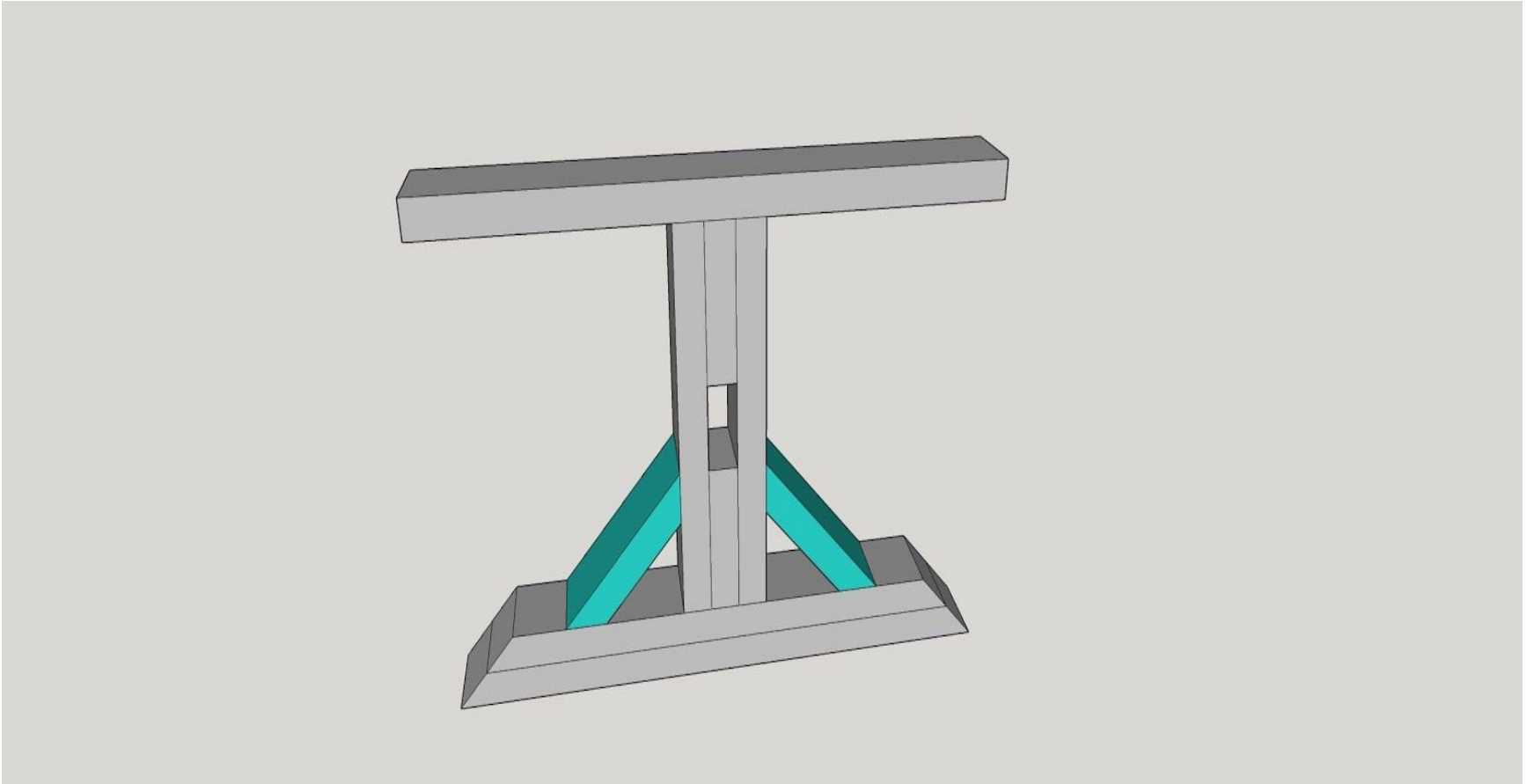

STEP 6: CUT AND LAYOUT TABLE TOP. FOR AN OUTDOOR TABLE BE SURE THERE ARE SMALL GAPS BETWEEN EACH BOARD.

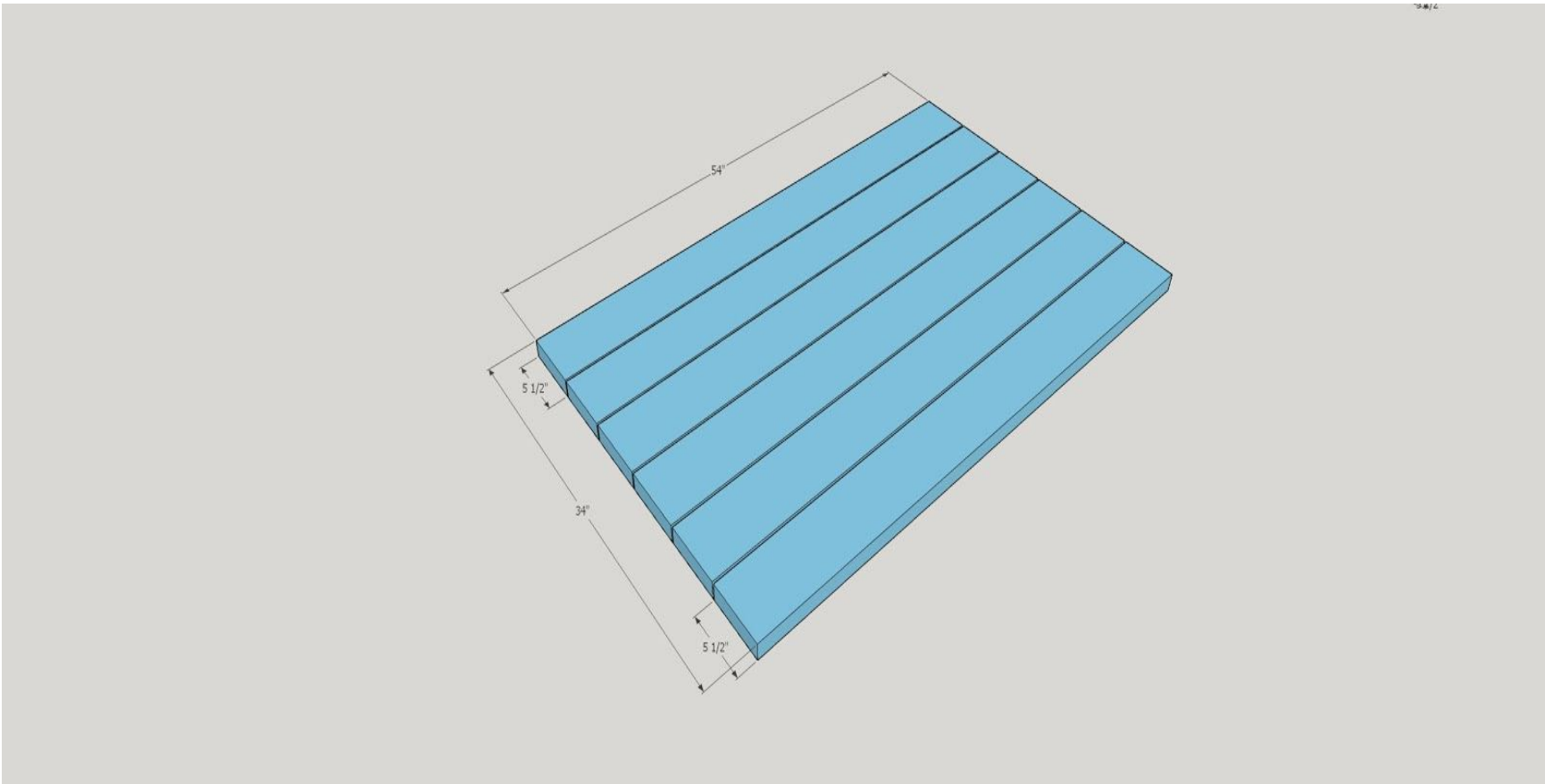

STEP 7: ATTACH TABLE TOP TO BASES USING SCREWS OR FIGURE 8 FASTENERS.

THIS VIDEO SHOWS YOU HOW TO USE THESE FASTENERS: <https://www.youtube.com/watch?v=lgjFdibI9Xc>

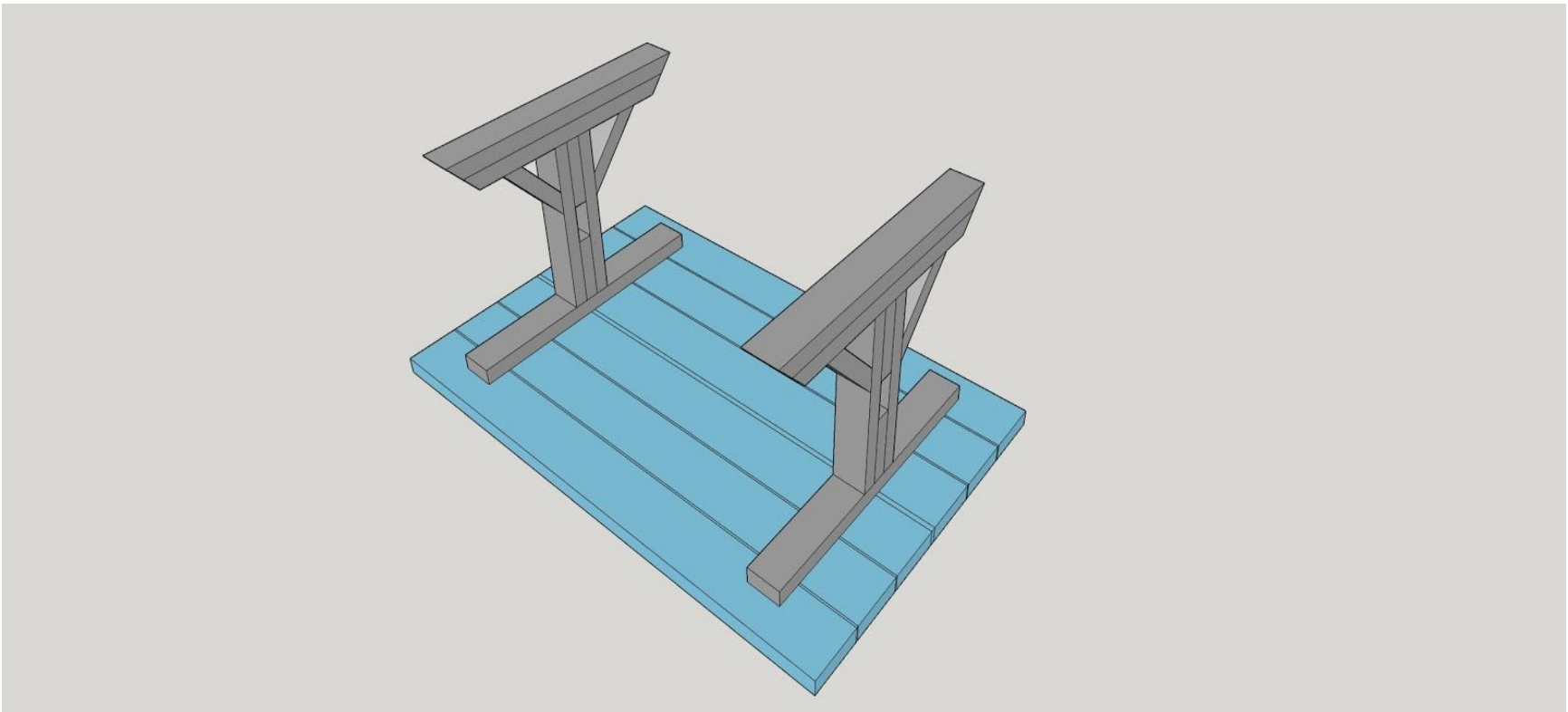

STEP 8: ATTACH FINAL ANGLED SUPPORTS.

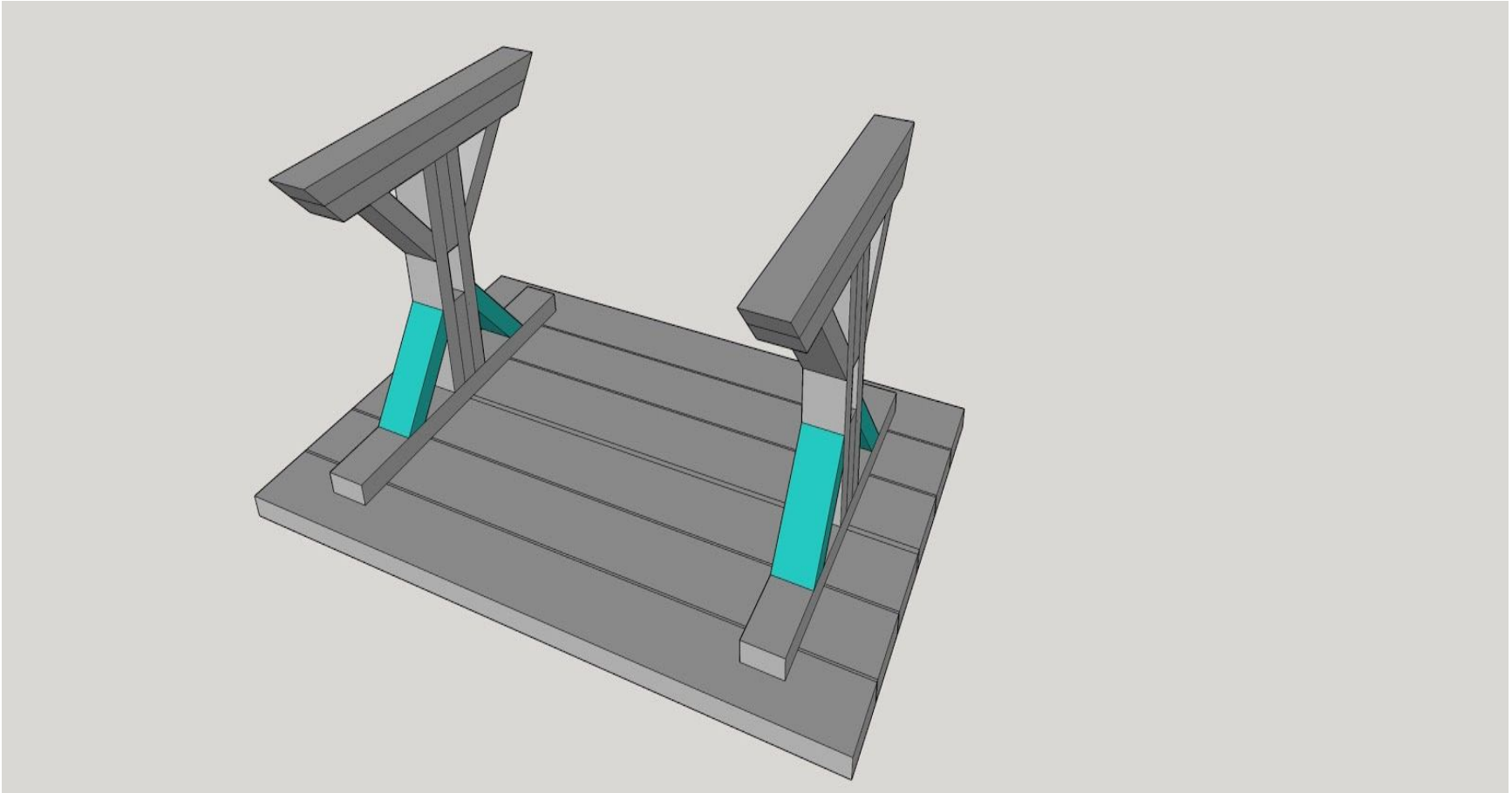

STEP 9: ADD CROSS SUPPORT (YOU MAY WANT TO DO THIS BEFORE ATTACHING THE TOP). KNOCK THE PIECE THROUGH WITH A HAMMER, THIS WILL GIVE YOUR TABLE EXTRA SUPPORT.

